

Parts List

- (1) Jaw Bar
- (2) Upper Jaw
- (3) Jack Bar
- (4) Lock Nut
- (5) Bearing
- (6) Cam Lock
- (7) Cam Nut
- (8) Cam Washer
- (9) Spring
- (10) Bolt
- (11) Optional Scissor Attachment

Warranty:

Knifemate's limited lifetime warranty guarantees that all Knifemate brand products are to be free from defects in materials and workmanship after retail purchase from an authorised dealer. Please retain proof of purchase for warranty purposes.

This guarantee excludes, but is not limited to, modification, unauthorised repair, misapplication or deliberate damage. It also excludes any consequential damage or inconvenience caused by failure of the product. Knifemate's liability is limited to the repair or replacement at Knifemate's discretion.



Patents Pending:
 Australia 2020203635
 New Zealand 765085
 United States of America 16/896,789

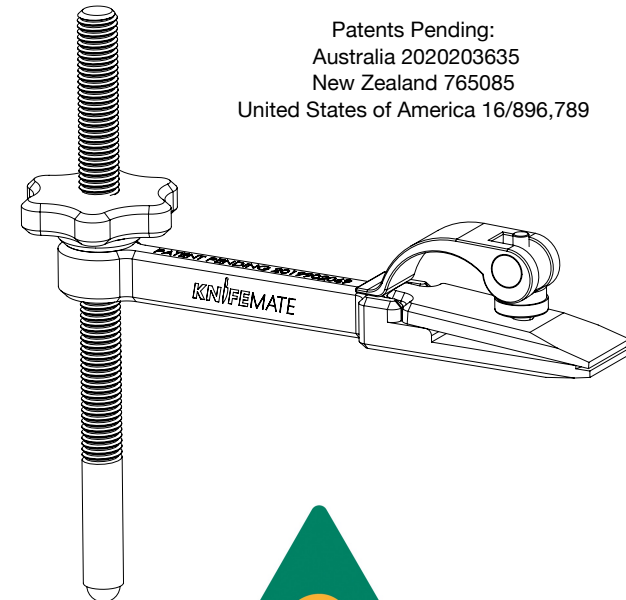

DESIGNED AND MANUFACTURED IN AUSTRALIA

www.blademates.com.au

Use of KNIFEMATE® for sharpening knives and most other blades. (A scissor sharpening attachment is also available.)

Loosen the cam, allowing enough room to place the spine of the blade between the upper and lower jaws.

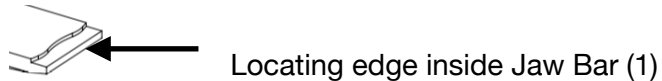

A. With the spine of the knife resting against the locating edge inside the lower jaw.

(Please refer to parts list for identification)

NB. If you have a large blade set it past the locating edge back into the jaws

B. Adjust the cam bolt (10) by hand and set the cam lever closed, do not over tighten. The jaws only need to hold the blade firmly for sharpening.

C. There are several ways to set your knife blade at the desired angle for sharpening.

- A mobile phone with a digital angle finder app can be used. Once you have established the chosen angle by adjusting the Jack Bar (3) you simply wind the Lock Nut (4) down firmly, no need to over tighten.
- Another easy and proven method is to colour the existing bevel on the blade with a felt tip pen. Pass the knife lightly over the stone a couple of times and examine the bevel. You will see if the angle needs to be adjusted by the residual colour on the bevel. Once you have established the chosen angle by adjusting the Jack Bar (3) you simply wind the Lock Nut (4) down firmly, no need to over tighten.



Use caution when handling sharp objects

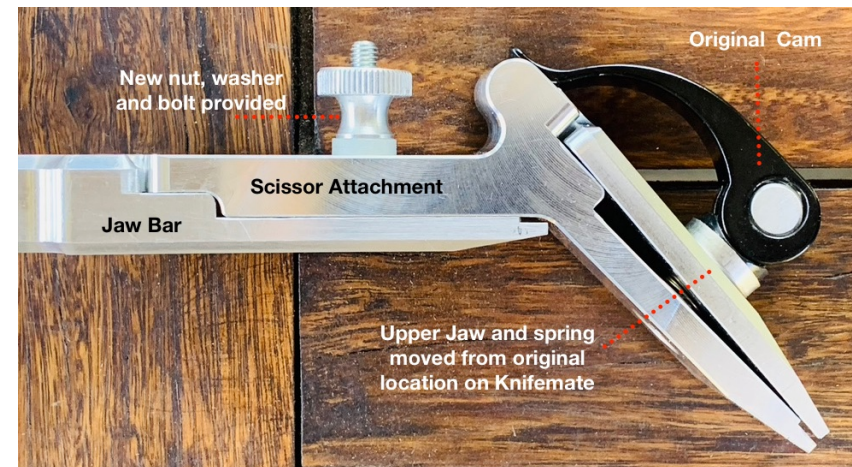

This attachment fits straight onto your Knifemate tool. Simply remove the top jaw and spring and install them onto the scissor attachment. A bolt nut and washer are provided to secure the attachment to your Knifemate tool. Remember do not over tighten the cam, you may damage the tool. Once the tool is assembled simply load your scissor blade into the tool, set the desired angle and commence sharpening.